

SN74LS20N

■ Product Introduction

The SN74LS20N is a digital integrated circuit that integrates two sets of four input and NAND gates.

■ Product Features

- Integrating two sets of four INPUT NAND gates
- Fully compatible with TTL/DTL input and output logic level
- Package : DIP14, SOP14

■ Product Applications

- Digital logic driver
- Industrial control applications
- Other application areas Battery-powered equipment

■ Package and Pin Assignment

SOP14 or DIP14.			
Pin NO	Pin Definition	Pin NO	Pin Definition
1	Input 1A	14	Supply VCC
2	Input 1B	13	Input 2D
3	NC	12	Input 2C
4	Input 1C	11	NC
5	Input 1D	10	Input 2B
6	Output 1Y	9	Input 2A
7	Supply GND	8	Output 2Y

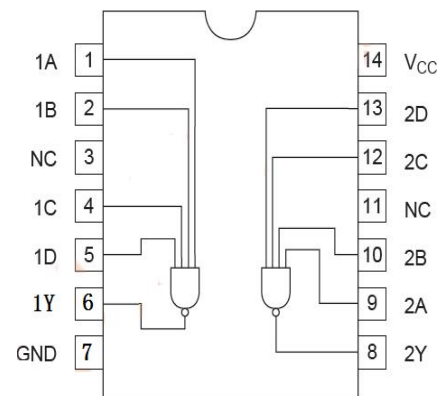

■ Absolute Maximum Ratings

Item	Symbol	Maximum Ratings	Unit
Supply voltage	V_{CC}	7	V
Input voltage	V_I	7	V
Power dissipation	P_D	500	mW
Operating temperature	T_A	0-70	°C
Storage temperature	T_S	-65-150	°C
welding temperature	T_W	260	°C, 10s

Note: the limit parameter is the limit value that cannot be exceeded under any condition. Once this limit is exceeded, it may cause physical damage such as deterioration of the product. At the same time, the chip can not be guaranteed to work properly when it is close to the limit parameters.

■ Block Diagram

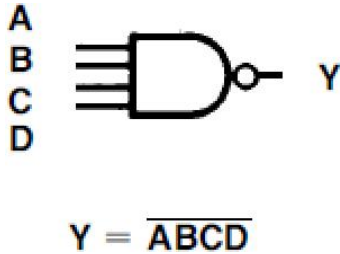

■ Function Table

Inputs				Output
A	B	C	D	Y
X	X	X	L	H
X	X	L	X	H
X	L	X	X	H
L	X	X	X	H
H	H	H	H	L

H = High Logic Level
 L = Low Logic Level
 X = Either Low or High Logic Level

■ Recommended Operating Conditions

Item	Symbol	Min	Tpy	Max	Unit
Supply voltage	V _{CC}	4.75	5	5.25	V
Input voltage	V _{IH}	2	—	—	V
	V _{IL}	—	—	0.7	V
Output current	I _{OH}	—	—	-400	μA
	I _{OL}	—	—	8	mA
Operating temperature	T _A	0	—	60	°C

■ Electrical Characteristics (T_A=25°C, Unless specified)

Item	Symbol	Min	Tpy	Max	Unit	Conditions	
Output voltage	V _{OH}	2.7	3.2	—	V	I _{OH} =-400μA	V _{CC} =4.75V, V _{IL} =0.7V
	V _{OL}	—	0.24	0.4	V	I _{OL} =4mA	V _{CC} =4.75V, V _{IH} =2V
		—	0.43	0.7		I _{OL} =8mA	
Input current	I _I	—	0.5	20	μA	V _{CC} =5.25V, V _I =7V	
	I _{IH}	—	0.01	20	μA	V _{CC} =5.25V, V _I =2.7V	
	I _{IL}	—	0.26	0.4	mA	V _{CC} =5.25V, V _I =0.4V	
Short-circuit output current	I _{OS(Notes1)}	—	-33	-100	mA	V _{CC} =5.25V	
Supply current	I _{CCH}	—	0.6	0.8	mA	V _{CC} =5.25V, all V _I =GND	
	I _{CCL}	—	1.8	2.2	mA	V _{CC} =5.25V, all V _I =V _{CC}	
Input clamp voltage	V _{IK}	—	0.8	-1.5	V	V _{CC} =4.75V, I _I = -18mA	

Note1: only one output port is short circuited each time, and the short circuit time is not more than one second.

■ Switching Characteristics (T_A=25°C, Unless specified)

Item	Symbol	Min	Tpy	Max	Unit	Conditions
Propagation delay time	t _{PLH}	—	17	—	ns	V _{CC} =5V, C _L =16pF, R _L =2K Ω
	t _{PHL}	—	10	—	ns	

■ Testing Method

1、Test Circuit

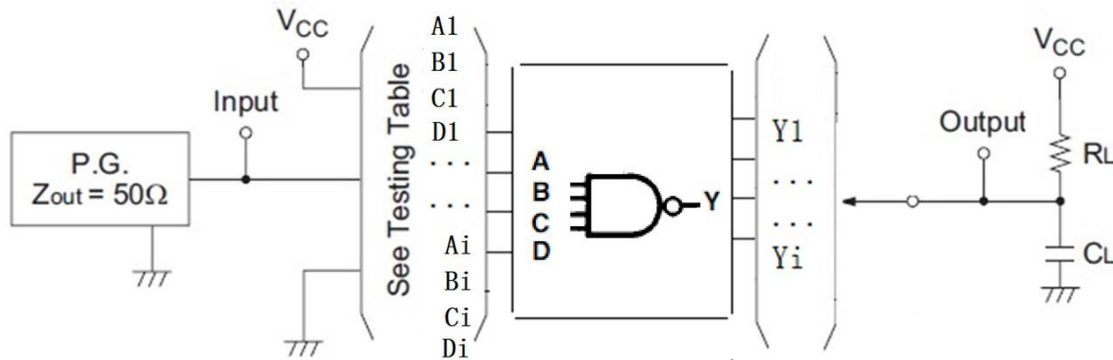

2、Waveform

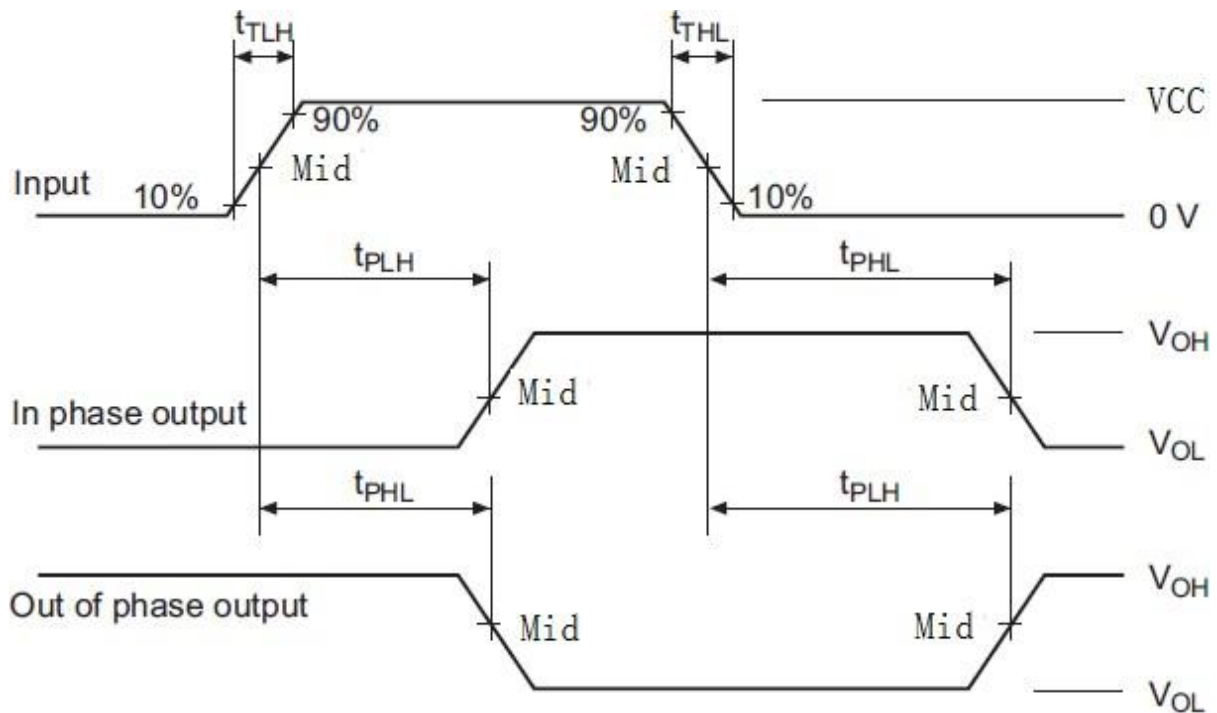

Note:

1. See Testing Table refers to the corresponding test items in the switch characteristic table.
2. the CL capacitor is an external patch capacitor (0603), which is connected to the output pin and the capacitor is near the chip GND.
3. Input: port input level, f=500kHz, D=50%, tTLH=tTHL or less 20ns;
4. Output: Y output test port (Out of Phase Output, In Phase Output)

■ Package Dimensions

Unit : mm /inch

DIP14

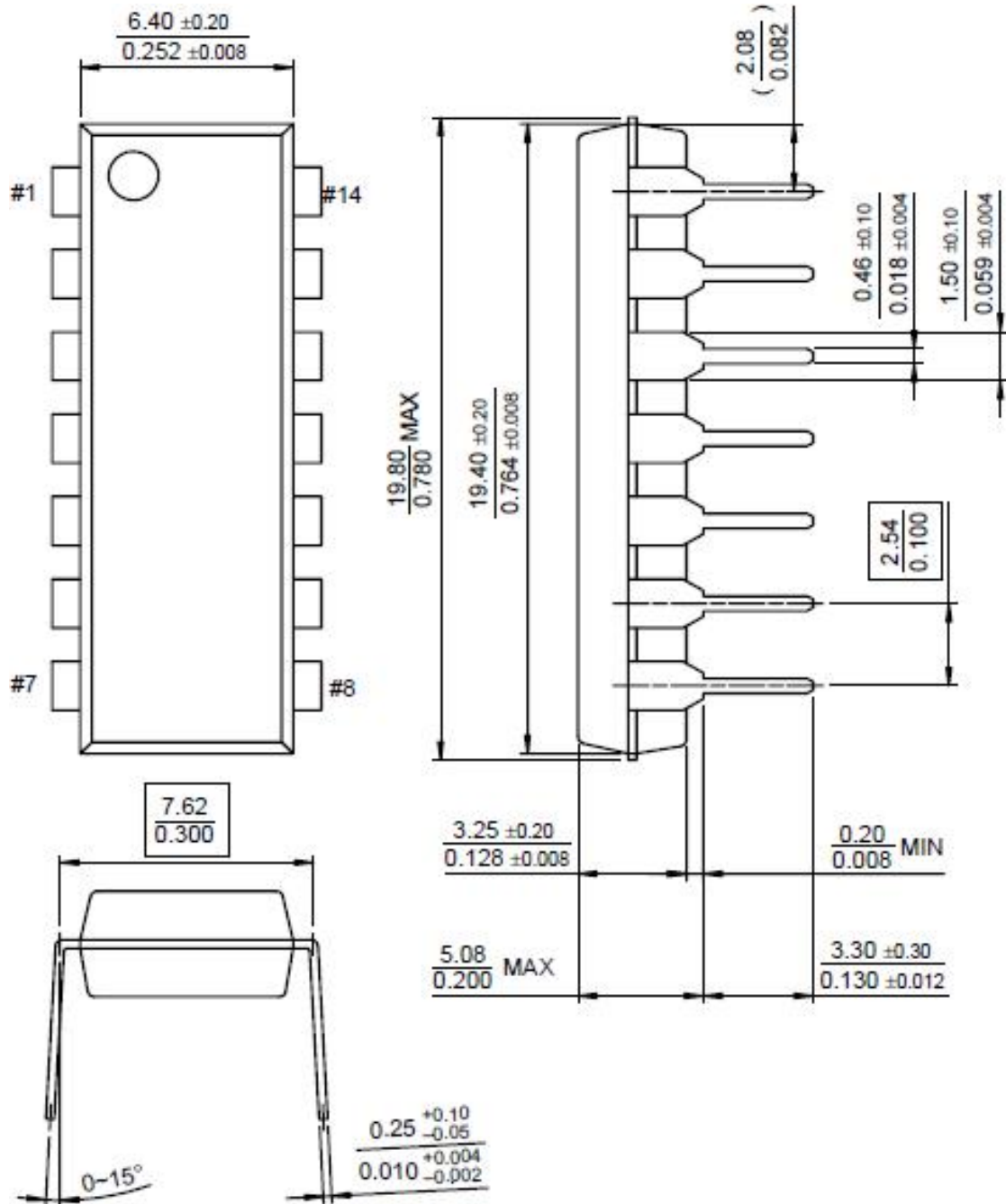

SOP14

